

YW

液下式排污泵

Liquid type Sewage Pumps



上海越然泵业有限公司

SHANGHAI YUERAN PUMP CO.,LTD.

一、产品概述

YW型无堵塞液下排污泵是在引进国内外先进技术的基础上,结合国内水泵的使用特点而研制成功的一代泵类产品,具有节能效果显著、防缠绕、无堵塞等特点,在排送固体颗粒和长纤维垃圾方面,具有独特效果。

该系列泵采用独特叶轮结构和新型机械密封,能有效地输送含有固体物和化学纤维,叶轮与传统叶轮相比,该泵叶轮采用单流道式或双流道式,它类似于同一截面大小相同的弯管,具有非常好的过流性,配以合理的蜗室,使得该泵具有效率高,过流效果好的特点,叶轮经动静平衡试验,使泵在运行中无振动。

该泵水力性能先进、成熟,产品经测试各项性能指标均达到有关标准规定,产品投放市场后以其独特的功效,可靠的性能,稳定的质量受到广大用户的欢迎和好评。

二、产品特点

- 1、采用大流道抗堵塞水力部件设计,大大提高污物通过能力,能有效地通过泵口径的5倍纤维物质和直径为泵口径约50%的固体颗粒。
- 2、设计合理,配套电机合理,效率高,节能效果显著。
- 3、机械密封采用双道串联密封,材质为硬质耐磨碳化钨,具有耐用、耐磨等特点,可以使泵安全连续运行8000小时以上。
- 4、泵结构紧凑,体积小,移动方便,安装简单等特点。
- 5、可根据用户需要配备液位自动控制柜,根据所需液位变化,自动控制泵的启动与停止,不需专人看管,使用极为方便。
- 6、泵为立式结构,工作时泵体浸在液体中因而很容易启动,不存在排气抽空问题,同时具有无泄漏等特点,液下深度可达0.5~7米。
- 7、接轴结构先进可靠,泵与电机采用联轴器联接,泵轴尺寸精密,保证了泵平稳运行,留有足够的安全系数。
- 8、在使用扬程范围内保证电机运行不过载。
- 9、泵有单管安装和双管安装两种,支承件有圆盘和方盘安装。

OUTLINE

Model YW under-liquid type sewage pump is a new generation product successfully researched and designed, integrates foreign advanced technology with the trait of domestic pump. Featuring a remarkable effect of energy saving, guard against the winding, non-clogging and automatic control. Have a distinctive effect to discharge solid particle and long fibre rubbish.

This series pump adopts special impeller structure and new mechanical seal, can transport the solid medium and long fibre effectively. Compared with traditional impeller, this impeller adopts the single channel or double channel, which is similar to identical cross section elbow that has the same size, and have very good ability of circulation. It can run without vibration through balance test of the impeller when collocate with the rational volute room.

The pump has a lead mature waterpower performance, through test, all performance indexes comply with relative requirements. After put for market, it receives great welcome and good comment support for special efficiency, reliable performance, and steady quality.

FEATURES OF PRODUCT

1. Adopt large-channel anti-jamming impeller structure, improve filth through ability, can be effective to pass 5 times of fibre through the caliber, diameter of pump require about 50% diameter of solid medium.
2. Reasonable design, reasonable necessary motor, high efficiency, effective energy-saving.
3. Mechanical seal adopts the new-type hard quality and is able to bear the rotten carbonization tungsten material, featuring a durable and wearable, can make pump run more than 8000 hours in succession safely.
4. Whole structure compactness; small, the little volume, move conveniently install easily. It does not need to build the pump house, slipping into water can work, reduce the fabrication cost.
5. Can collocate the switch board of full-automatic safe protection based on the needs of user, protect the pump when leak water, leak electricity, overload and ultra warm definitely, improve security and dependability of the products.
6. The pump is vertical structure, it is easily to start, because pump body is under water, inexistence exhaust vacuum phenomena and has no leakage, and the underwater depth reach 5-7m.
7. Connected shaft structure is advanced and certain, the pump and motor choose clutch to make connect, the size of shaft is exactitude ensure the stable running.
8. Guarantee the motor do not overload within the range of the whole head.
9. Pump have single pipe and double pipe installation, backup piece have disk and square plate installation.

三、产品适用场合

- 1、工厂商业严重污染废水的排放。
- 2、城市污水处理厂排水系统。
- 3、住宅区的污水排水站。
- 4、人防系统排水站。
- 5、医院、宾馆的污水排放。
- 6、市政工程、建筑工地。
- 7、勘探、矿山配套附机。
- 8、农村沼气池农田灌溉。
- 9、自来水厂的给水装置。

APPLICABLE FIELDS

- 1、Factories and commercial zone have serious polluted water emissions.
- 2、Urban sewage treatment plant's drainage system.
- 3、Residential district sewage row of water station.
- 4、Civil air defense system row of water station.
- 5、Polluted water drainage of hospital and hotel.
- 6、Public work, construction site.
- 7、Assembly machines on exploration and mine
- 8、Countryside methane-generating pit, irrigation
- 9、The water supply equipment in water station.

四、泵使用条件

- 1、介质温度不超过60℃，重度为1~1.3Kg/dm³，PH值在5~9范围内。
- 2、一般情况下，泵必须在使用扬程范围内使用，保证电机不超载，如需在全扬程范围使用，应在订货时另行注明，以便厂家制造。
- 3、在运行过程泵电机电流不得超过电机的额定电流。
- 4、如有特殊的温度、介质等要求，请在订货时注明输送介质的详细情况，以便厂家制造。

CONDITIONS OF USE

1. The medium temperature should not be over 60℃, density is 1.0~1.3 kg/dm³, PH value is within 5~9.
2. Pump has no an inner self-flowing circulation cooling system, the motor part outsides liquid should not exceed its 1/2.
3. Generally, ensure the motor do not overload within the range of using head. If it is necessary to work under all head, please make a separate note in advance so as to manufacture.
4. If any special requirement on temperature and medium comes, please make a separate detailed note on transported medium in advance so as to manufacture.

五、型号意义 MODEL MEANIG

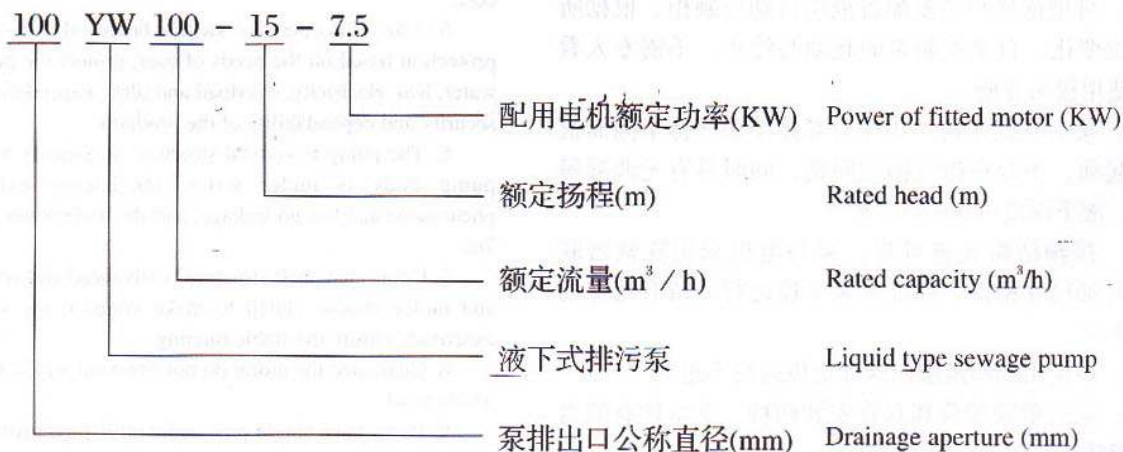

六、结构示意图 STRUCTURE DESCRIPTION

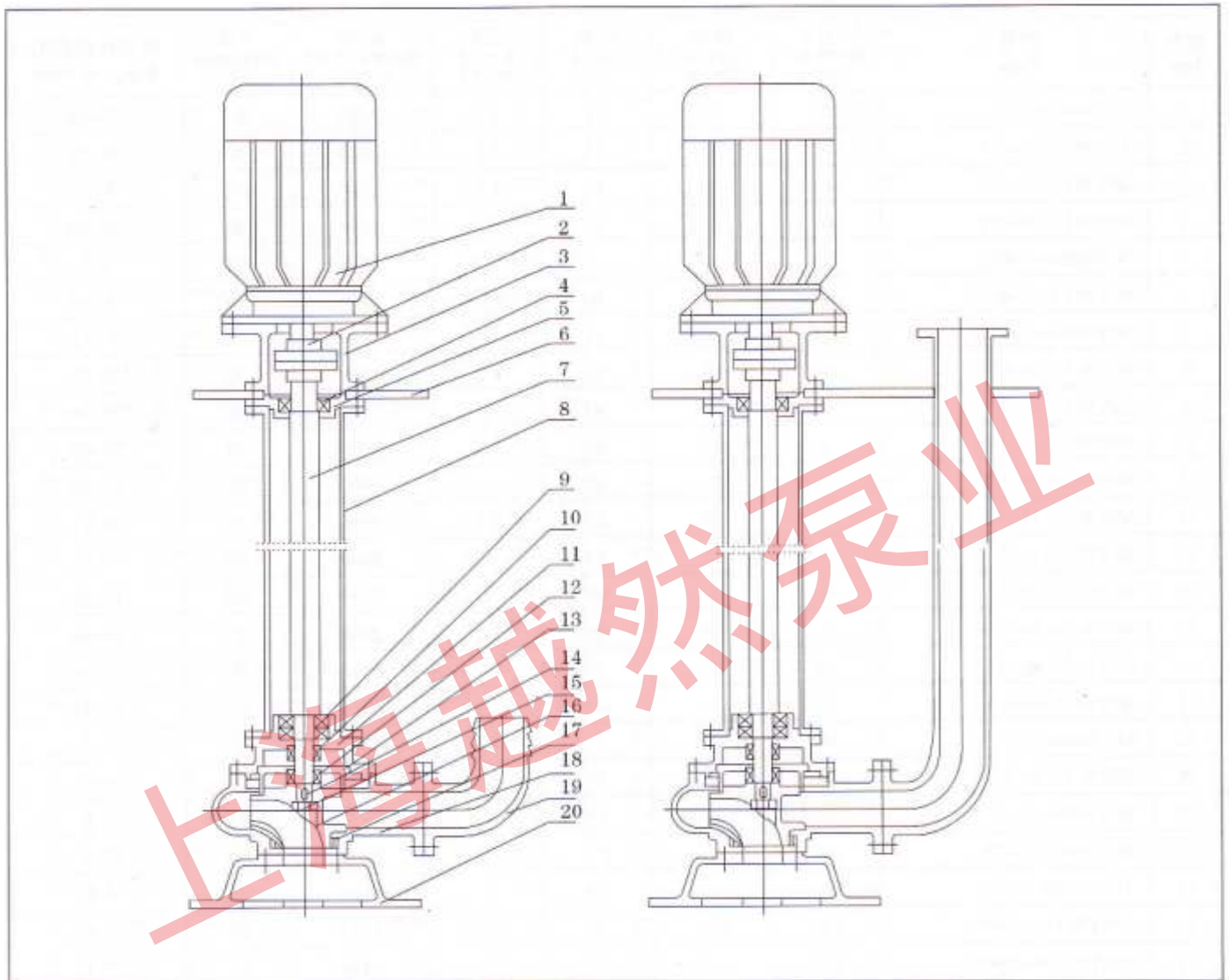

1	电机	Motor	8	支撑管	Sustaining tube	15	叶轮螺母	Impeller nut
2	联轴器	Coupling	9	下轴承	Lower bearing	16	叶轮	Impeller
3	电机座	Motor foundation	10	上机械密封	Upper mechanical seal	17	密封环	Seal ring
4	上轴承	Upper bearing	11	油室	Oil room	18	泵体	Pump body
5	上轴承座	Upper bearing base	12	机械密封	Mechanical seal	19	出水管	Outlet pipe
6	安装盘	Subpanel	13	后盖板	Rear end plate	20	底盘	Chassis
7	加长轴	Longer shaft	14	键	Key			

七、性能参数 PERFORMANCE

序号 No.	型号 Type	口径 Diameter (mm)	流量 Capacity (m ³ /h)	扬程 Head (m)	功率 Power (KW)	转速 Rotary speed (r/min)	效率 Efficiency (%)	使用扬程范围 Range of head
1	25YW8-22-1.1	25	8	22	1.1	2825	38.5	10-22
2	32YW12-15-1.1	32	12	15	1.1	2825	40	8-15
3	40YW15-15-1.5	40	15	15	1.5	2840	45.1	6-15
4	40YW15-30-2.2	40	15	30	2.2	2840	48	15-30
5	50YW20-7-0.75	50	20	7	0.75	1390	54	3-7
6	50YW10-10-0.75	50	10	10	0.75	1390	56	4-10
7	50YW20-15-1.5	50	20	15	1.5	2840	55	6-15
8	50YW15-25-2.2	50	15	25	2.2	2840	56	10-25
9	50YW18-30-3	50	18	30	3	2880	58	15-30
10	50YW25-32-5.5	50	25	32	5.5	2900	53	17-32
11	50YW20-40-7.5	50	20	40	7.5	2900	55	20-40
12	65YW25-15-2.2	65	25	15	2.2	2840	52	6-15
13	65YW37-13-3	65	37	13	3	2880	55	6-13
14	65YW25-30-4	65	25	30	4	2890	58	15-30
15	65YW30-40-7.5	65	30	40	7.5	2900	56	20-40
16	65YW35-50-11	65	35	50	11	2930	60	35-50
17	65YW35-60-15	65	35	60	15	2930	63	40-60
18	80YW40-7-2.2	80	40	7	2.2	1420	52	3-7
19	80YW43-13-3	80	43	13	3	2880	50	5-13
20	80YW40-15-4	80	40	15	4	2890	57	6-15
21	80YW65-25-7.5	80	65	25	7.5	2900	56	12-25
22	100YW80-10-4	100	80	10	4	1440	62	4-10
23	100YW110-10-5.5	100	110	10	5.5	1440	66	5-10
24	100YW100-15-7.5	100	100	15	7.5	1440	67	8-15
25	100YW85-20-7.5	100	85	20	7.5	1440	68	10-20
26	100YW100-25-11	100	100	25	11	1460	65	10-25
27	100YW100-30-15	100	100	30	15	1460	66	12-30
28	100YW100-35-18.5	100	100	35	18.5	1470	65	15-35
29	125YW130-15-11	125	130	15	11	1460	62	7-15
30	125YW130-20-15	125	130	20	15	1460	63	10-20
31	150YW145-9-7.5	150	145	9	7.5	1440	63	4-9
32	150YW180-15-15	150	180	15	15	1460	65	5-15
33	150YW180-20-18.5	150	180	20	18.5	1470	75	8-20
34	150YW180-25-22	150	180	25	22	1470	76	12-25
35	150YW130-30-22	150	130	30	22	1470	75	15-30
36	150YW180-30-30	150	180	30	30	1470	73	15-30
37	150YW200-30-37	150	200	30	37	1480	70	13-30

性能参数 PERFORMANCE

序号 No.	型号 Type	口径 Diameter (mm)	流量 Capacity (m ³ /h)	扬程 Head (m)	功率 Power (KW)	转速 Rotary speed (r/min)	效率 Efficiency (%)	使用扬程范围 Range of head
38	200YW300-7-11	200	300	7	11	970	73	3-7
39	200YW250-11-15	200	250	11	15	970	74	4-11
40	200YW400-10-22	200	400	10	22	1470	76	5-10
41	200YW400-13-730	200	400	13	30	1470	73	6-13
42	200YW250-15-18.5	200	250	15	18.5	1470	72	7-15
43	200YW300-15-22	200	300	15	22	1470	73	8-15
44	200YW250-22-30	200	250	22	30	1470	71	12-22
45	200YW350-25-37	200	350	25	37	1980	75	10-25
46	200YW400-30-45	200	400	30	45	1480	70	13-30
47	250YW600-9-30	250	600	9	30	980	74	3-9
48	250YW600-12-37	250	600	12	37	1480	78	5-12
49	250YW600-15-45	250	600	15	45	1480	75	6-15
50	250YW600-20-55	250	600	20	55	1480	73	8-20
51	250YW600-25-75	250	600	25	75	1480	73	12-25
52	300YW800-12-45	300	800	12	45	980	76	5-12
53	300YW500-15-45	300	500	15	45	980	70	7-15
54	300YW800-15-55	300	800	15	55	980	73	8-15
55	300YW600-20-55	300	600	20	55	980	75	10-20
56	300YW800-20-75	300	800	20	75	980	78	12-20
57	300YW950-20-90	300	950	20	90	980	80	11-20
58	300YW1000-25-110	300	1000	25	110	980	82	12-25
59	350YW1100-10-55	350	1100	10	55	980	84.5	4-10
60	350YW1500-15-90	350	1500	15	90	980	82.5	6-15
61	350YW1200-18-90	350	1200	18	90	980	83.1	8-18
62	350YW1100-28-132	350	1100	28	132	740	83.2	15-28
63	350YW1000-36-160	350	1000	36	160	740	78.5	20-36
64	400YW1500-10-75	400	1500	10	75	980	82.1	3-10
65	400YW2000-15-132	400	2000	15	132	740	85.5	6-15
66	400YW1700-22-160	400	1700	22	160	740	82.1	10-22
67	400YW1500-26-160	400	1500	26	160	740	83.5	12-26
68	400YW1700-30-200	400	1700	30	200	740	83.5	15-30
69	400YW1800-32-250	400	1800	32	250	740	82.1	17-32
70	500YW2500-10-110	500	2500	10	110	740	82	2-10
71	500YW2600-15-160	500	2600	15	160	740	83	4-15
72	500YW2400-22-220	500	2400	22	220	740	84	8-22
73	500YW2600-24-250	500	2600	24	250	740	82	10-24

八、安装尺寸表 INSTALLATION DIMENSION

序号 No.	型号 Type	D	D1	DN	n-d	B	H1	L	h	H2	H	A
1	25YW8-22-1.1	120	90	25	4-Φ14	305	110	1-5	16	70	380	195
2	32YW12-15-1.1	120	90	32	4-Φ14	305	110	1-5	16	70	380	195
3	40YW15-15-1.5	130	100	40	4-Φ14	340	120	1-5	18	80	400	215
4	40YW15-30-2.2	130	100	40	4-Φ14	340	120	1-5	18	80	400	215
5	50YW20-7-0.75	140	110	50	4-Φ14	370	125	1-5	18	80	380	225
6	50YW10-10-0.75	140	110	50	4-Φ14	370	125	1-5	18	80	380	225
7	50YW20-15-1.5	140	110	50	4-Φ14	345	120	1-5	18	80	410	215
8	50YW15-25-2.2	140	110	50	4-Φ14	345	120	1-5	18	80	430	215
9	50YW18-30-3	140	110	50	4-Φ14	370	125	1-5	18	80	450	225
10	50YW25-32-5.5	140	110	50	4-Φ14	410	155	1-5	20	80	500	255
11	50YW20-40-7.5	140	110	50	4-Φ14	410	155	1-5	20	80	520	255
12	65YW25-15-2.2	160	130	65	4-Φ14	410	125	1-5	18	80	430	260
13	65YW37-13-3	160	130	65	4-Φ14	410	125	1-5	18	80	450	260
14	65YW25-30-4	160	130	65	4-Φ14	420	125	1-5	18	80	460	270
15	65YW30-40-7.5	160	130	65	4-Φ14	450	155	1-5	20	80	500	290
16	65YW35-50-11	160	130	65	4-Φ14	460	165	1-5	22	100	600	290
17	65YW35-60-15	160	130	65	4-Φ14	460	165	1-5	22	100	630	290
18	80YW40-7-2.2	190	150	80	4-Φ18	490	165	1-5	22	100	430	325
19	80YW43-13-3	190	150	80	4-Φ18	445	165	1-5	22	100	450	295
20	80YW40-15-4	190	150	80	4-Φ18	445	165	1-5	22	100	460	395
21	80YW65-25-7.5	190	150	80	4-Φ18	490	165	1-5	22	100	500	325
22	100YW80-10-4	210	170	100	4-Φ18	620	175	1-7	22	100	460	420
23	100YW110-10-5.5	210	170	100	4-Φ18	650	185	1-7	22	100	520	420
24	100YW100-15-7.5	210	170	100	4-Φ18	650	185	1-7	22	~100	550	420
25	100YW85-20-7.5	210	170	100	4-Φ18	650	185	1-7	22	100	550	420
26	100YW100-25-11	210	170	100	4-Φ18	710	210	1-7	22	100	630	450
27	100YW100-30-15	210	170	100	4-Φ18	740	225	1-7	22	100	740	485
28	100YW100-35-18.5	210	170	100	4-Φ18	740	225	1-7	22	100	800	485
29	125YW130-15-11	240	200	125	8-Φ18	740	225	1-7	22	140	600	470
30	125YW130-20-15	240	200	125	8-Φ18	740	225	1-7	22	140	660	470
31	150YW145-9-7.5	265	225	150	8-Φ18	740	225	1-7	22	140	530	480
32	150YW180-15-15	265	225	150	8-Φ18	770	225	1-7	22	140	680	480
33	150YW180-20-18.5	265	225	150	8-Φ18	780	225	1-7	22	140	730	480
34	150YW180-25-22	265	225	150	8-Φ18	780	225	1-7	22	140	750	480
35	150YW130-30-22	265	225	150	8-Φ18	860	225	1-7	22	140	750	520
36	150YW180-30-30	265	225	150	8-Φ18	860	225	1-7	22	140	780	520
37	150YW200-30-37	265	225	150	8-Φ18	860	225	1-7	22	140	780	520

安装尺寸表 INSTALLATION DIMENSION

C×E	Cl×E1	F	G	n-a	Φe	Φe1
600×320	550×270	300	100	4-Φ14	300	265
600×320	550×270	300	105	4-Φ14	300	265
600×320	550×270	300	105	4-Φ14	300	265
600×320	550×270	300	105	4-Φ14	300	265
600×320	550×270	300	105	4-Φ14	300	265
600×320	550×270	300	105	4-Φ14	300	265
600×320	550×270	300	105	4-Φ14	300	265
600×320	550×270	300	105	4-Φ14	300	265
600×320	550×270	300	105	4-Φ14	300	265
600×320	550×270	300	105	4-Φ14	350	300
600×320	550×270	300	105	4-Φ14	350	300
600×320	550×270	300	105	4-Φ14	300	265
600×320	550×270	300	105	4-Φ14	300	265
600×320	550×270	300	105	4-Φ14	300	265
600×320	550×270	300	105	4-Φ14	300	265
600×320	550×270	300	105	4-Φ14	350	300
600×320	550×270	300	105	4-Φ18	500	300
600×320	550×270	300	105	4-Φ18	500	420
600×320	550×270	300	105	4-Φ14	300	420
600×320	550×270	300	105	4-Φ14	300	265
600×320	550×270	300	105	4-Φ14	300	265
600×320	550×270	300	105	4-Φ18	350	265
720×380	610×320	390	130	4-Φ14	300	300
720×380	660×320	390	130	4-Φ14	350	265
720×380	660×320	390	130	4-Φ14	350	300
720×380	660×320	390	130	4-Φ14	350	300
720×380	660×320	390	130	4-Φ18	500	300
720×380	660×320	390	130	4-Φ18	500	420
720×380	660×320	390	130	4-Φ23	600	420
500×420	740×360	430	160	4-Φ18	500	520
500×420	740×360	430	160	4-Φ18	500	420
500×420	740×360	430	160	4-Φ18	350	420
500×420	740×360	430	160	4-Φ18	500	420
500×420	740×360	430	160	4-Φ23	600	520
500×420	740×360	430	160	4-Φ23	600	520
500×420	740×360	430	160	4-Φ23	600	520
500×420	740×360	430	160	4-Φ23	600	520
500×420	740×360	430	160	6-Φ18	760	620
500×420	740×360	430	160	6-Φ18	700	620

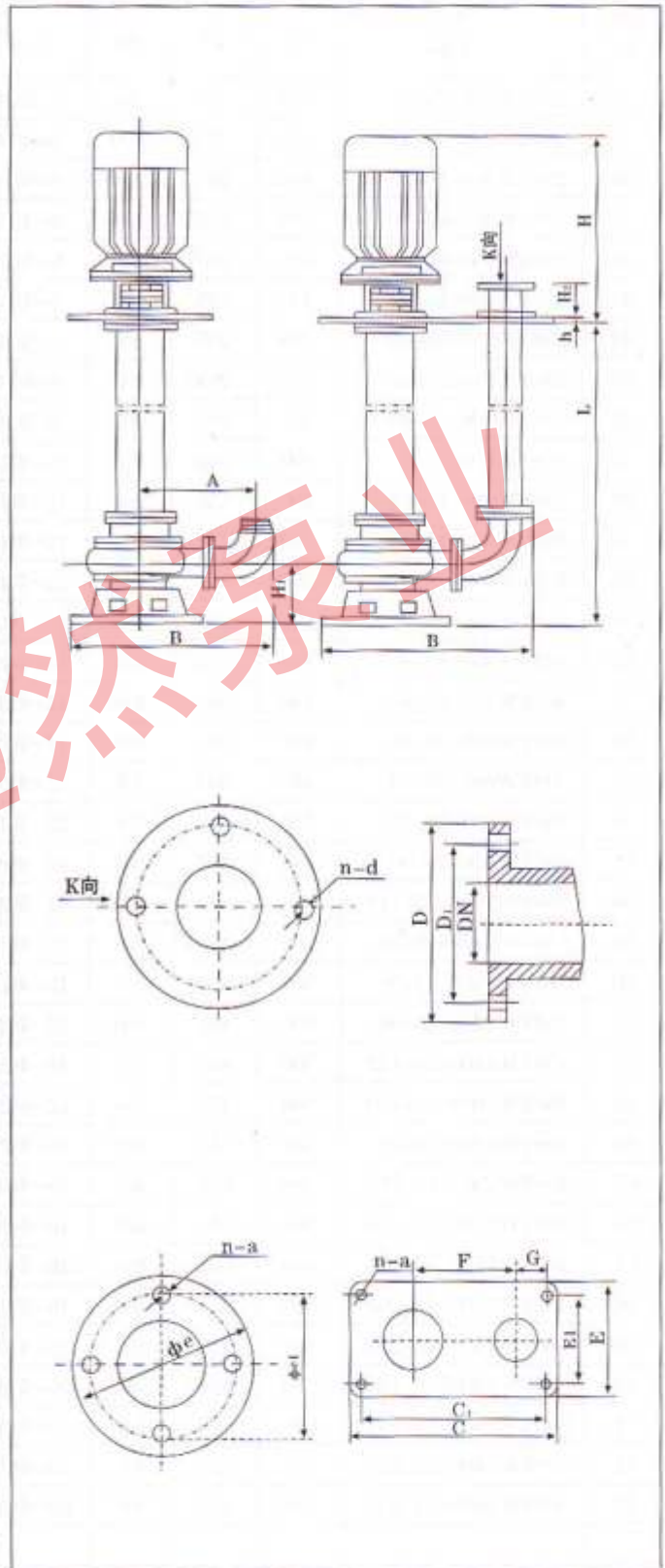

安装尺寸表 INSTALLATION DIMENSION

序号 No.	型号 Type	D	D1	DN	n-d	B	H1	L	h	H2	H	A
38	200YW300-7-11	335	295	200	8-Φ18	900	275	1-7	24	200	740	560
39	200YW250-11-15	335	295	200	8-Φ18	900	275	1-7	24	200	805	560
40	200YW400-10-22	335	295	200	8-Φ18	900	275	1-7	24	200	850	560
41	200YW400-13-30	335	295	200	8-Φ18	900	275	1-7	24	200	900	560
42	200YW250-15-18.5	335	295	200	8-Φ18	900	275	1-7	24	200	836	560
43	200YW300-15-22	335	295	200	8-Φ18	900	275	1-7	24	200	850	560
44	200YW250-22-30	335	295	200	8-Φ18	900	275	1-7	24	200	900	560
45	200YW350-25-37	335	295	200	8-Φ18	900	275	1-7	24	200	950	560
46	200YW400-30-45	335	295	200	8-Φ18	900	275	1-7	24	200	1005	580
47	250YW600-9-30	390	350	250	12-Φ18	1100	320	1-7	25	250	850	650
48	250YW600-12-37	390	350	250	12-Φ18	1100	320	1-7	25	250	950	650
49	250YW600-15-45	390	350	250	12-Φ18	1100	320	1-7	25	250	1010	650
50	250YW600-20-55	390	350	250	12-Φ18	1100	320	1-7	25	250	1250	650
51	250YW600-25-75	390	350	250	12-Φ18	1100	320	1-7	25	250	1310	650
52	300YW800-12-45	440	395	300	12-Φ23	1200	400	1-7	28	250	1200	800
53	300YW500-15-45	440	395	300	12-Φ23	1200	400	1-7	28	250	1200	800
54	300YW800-15-55	440	395	300	12-Φ23	1200	400	1-7	28	250	1250	800
55	300YW600-20-55	440	395	300	12-Φ23	1200	400	1-7	28	250	1250	800
56	300YW800-20-75	440	395	300	12-Φ23	1200	400	1-7	28	250	1350	800
57	300YW950-20-90	440	395	300	12-Φ23	1200	400	1-7	28	250	1420	800
58	300YW1000-25-110	440	395	300	12-Φ23	1200	400	1-7	28	250	1560	800
59	350YW1100-10-55	500	460	350	12-Φ23	1350	450	1-7	30	250	1300	950
60	350YW1500-15-90	500	460	350	12-Φ23	1350	450	1-7	30	250	1450	950
61	350YW1200-18-90	500	460	350	12-Φ23	1350	450	1-7	30	250	1450	950
62	350YW1100-28-132	500	460	350	12-Φ23	1350	450	1-7	30	250	1600	950
63	350YW1000-36-160	500	460	350	12-Φ23	1350	450	1-7	30	250	1600	950
64	400YW1500-10-75	560	515	400	16-Φ26	1480	510	1-7	30	250	1400	950
65	400YW2000-15-132	560	515	400	16-Φ26	1480	510	1-7	30	250	1600	950
66	400YW1700-22-160	560	515	400	16-Φ26	1480	510	1-7	30	250	1620	950
67	400YW1500-26-160	560	515	400	16-Φ26	1480	510	1-7	30	250	1630	950
68	400YW1700-30-200	560	515	400	16-Φ26	1480	510	1-7	30	250	1750	950
69	400YW1800-32-250	560	515	400	16-Φ26	1480	510	1-7	30	250	1860	950
70	500YW2500-10-110	670	620	500	20-Φ26	2010	580	1-7	30	250	1600	1200
71	500YW2600-15-160	670	620	500	20-Φ26	2010	580	1-7	30	250	1620	1200
72	500YW2400-22-220	670	620	500	20-Φ26	2010	580	1-7	30	250	1750	1200
73	500YW2600-24-250	670	620	500	20-Φ26	2010	580	1-7	30	250	1860	1200

安装尺寸表 INSTALLATION DIMENSION

C×E	C1×E1	F	G	n-a	Φe	Φe1
1000×500	920×420	500	200	4-Φ18	500	420
1000×500	920×420	500	200	4-Φ18	500	420
1000×500	920×420	500	200	4-Φ23	600	520
1000×500	920×420	500	200	6-Φ18	700	620
1000×500	920×420	500	200	4-Φ23	600	520
1000×500	920×420	500	200	4-Φ23	600	520
1000×500	920×420	500	200	6-Φ18	700	620
1000×500	920×420	500	200	6-Φ18	700	620
1000×500	920×420	500	200	6-Φ20	750	680
1300×750	1220×680	500	250	6-Φ20	750	680
1300×750	1220×680	500	250	6-Φ20	750	680
1300×750	1220×680	500	250	6-Φ20	750	680
1300×750	1220×680	500	250	6-Φ20	750	680
1300×750	1220×680	500	250	6-Φ20	750	680
1400×750	1300×680	560	320	6-Φ20	750	680
1400×750	1300×680	560	320	6-Φ20	750	680
1400×750	1300×680	560	320	6-Φ20	750	680
1400×750	1300×680	560	320	6-Φ20	750	680
1400×750	1300×680	560	320	6-Φ20	750	680
1400×750	1300×680	560	320	6-Φ20	750	680
1400×750	1300×680	560	320	6-Φ20	750	680
1400×750	1300×680	560	320	6-Φ20	750	680
1500×750	1400×680	670	400	6-Φ20	750	680
1500×750	1400×680	670	400	6-Φ20	750	680
1500×750	1400×680	670	400	6-Φ20	750	680
1500×750	1400×680	670	400	6-Φ20	750	680
1500×750	1400×680	670	400	6-Φ20	750	680
1500×750	1400×680	670	400	6-Φ20	750	680
1500×750	1400×680	670	400	6-Φ20	750	680
1500×750	1400×680	670	400	6-Φ20	750	680
1500×750	1400×680	670	400	6-Φ20	750	680
1500×750	1400×680	670	400	6-Φ20	750	680
1500×750	1400×680	670	400	6-Φ20	750	680
1500×750	1400×680	670	400	6-Φ20	750	680
1500×750	1400×680	670	400	6-Φ20	750	680
1500×750	1400×680	670	400	6-Φ20	750	680
1800×900	1700×800	1000	300	6-Φ20	900	800
1800×900	1700×800	1000	300	6-Φ20	900	800
1800×900	1700×800	1000	300	6-Φ20	900	800
1800×900	1700×800	1000	300	6-Φ20	900	800

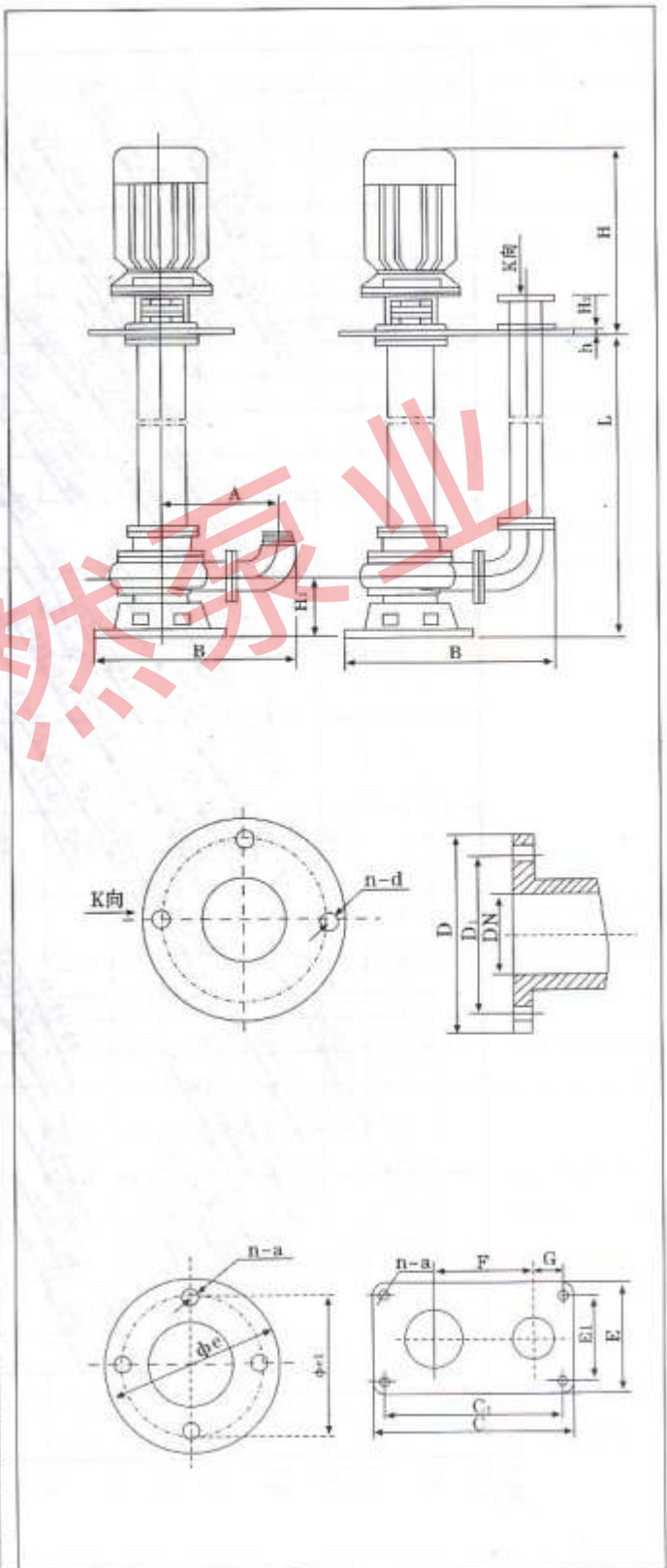

九、型谱图 ATLAS OF STYLE

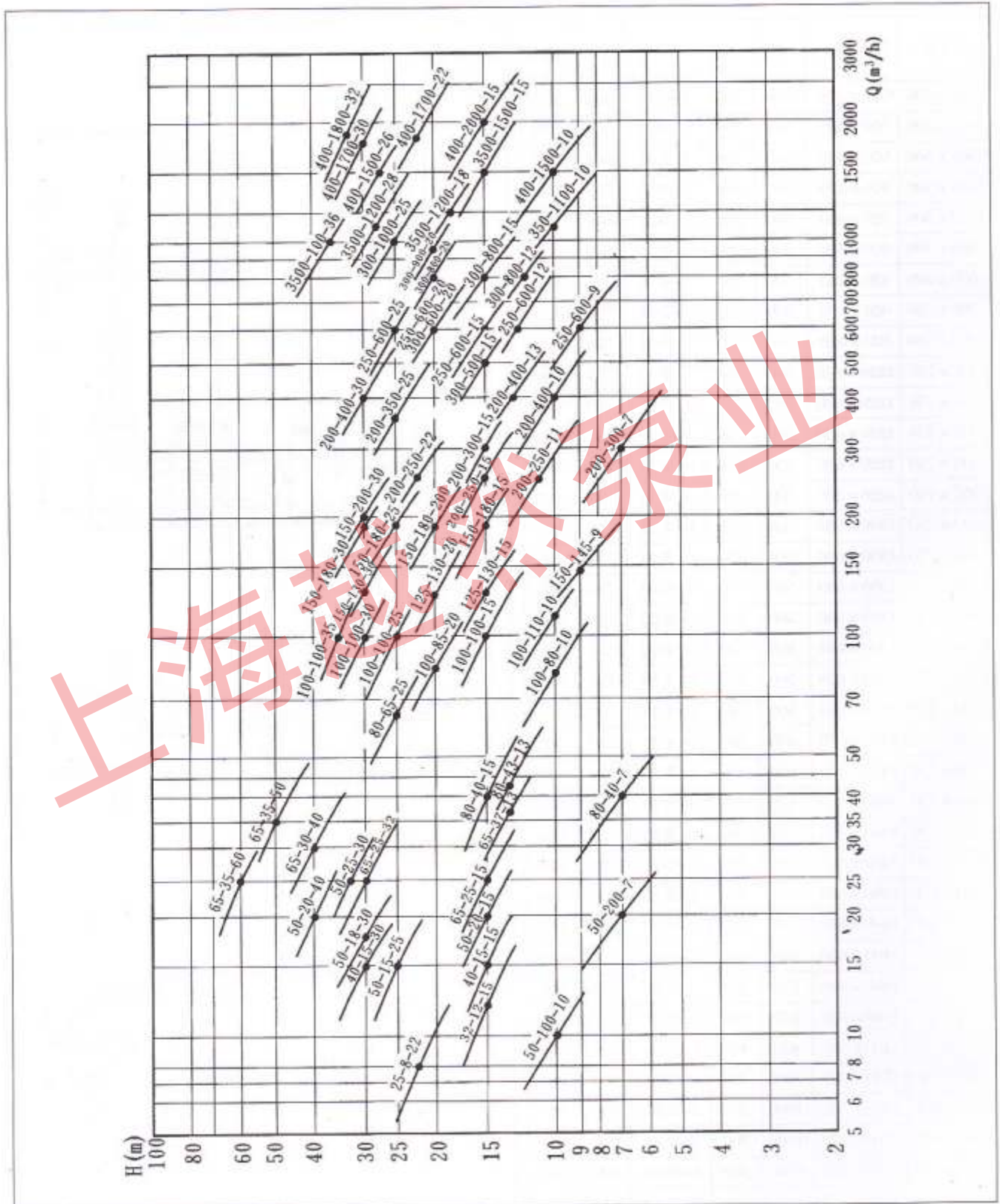

十、泵使用方法及注意事项

1. 泵使用前应仔细检查泵和电机有无损伤，检查紧固件紧固情况。
2. 盘动泵检查有无磨擦声，同时检查泵轴与电机轴同心度，两联轴节外圆偏差数不超过0.5mm。
3. 接泵出液口之管路，应另设支架，不允许将其重量加于泵体上。
4. 水泵在无特殊情况必须配备全自动水泵控制柜，切勿直接挂电网或使用闸刀开关来接通电流，确保水泵正常运行。
5. 不得将水泵长期处于低扬程状态下运行(一般使用扬程不得低于额定扬程的60%)，最好能控制在建议使用扬程范围以内，以防水泵因超载而烧坏电机。

十一、维护保养

1. 水泵应有专人管理与使用，并定期检查水泵的电路和水泵工作是否正常。
2. 每次使用特别是用于较稠较粘的浆液后，应将水泵放在清水中运转数分钟，防止泵内留下沉积物，保证水泵的清洁。
3. 在常规状态下，泵每使用300~500小时后应加注或更换油室中机油(10~30#机油)，使机械密封保持良好的润滑状态，提高机械密封的使用寿命。
4. 叶轮和泵体之间的密封环具有密封功能，如密封环损坏将直接影响泵的性能，必要时应更换。

APPLICATION AND NOTICE

1. Before working, should check carefully if any damage with the cable, if any looseness or fall-off with the fasteners, if any deformation or damage with pump during transport, storage and installation.
2. Hand pump check if there is stridulation, and concentricity of pump shaft with motor shaft, outside deviation on both coupling do not exceed 0.5mm.
3. The pipeline of outlet should install another bracket, cannot put on the pump body.
4. Generally, should assembly full-automatic control cabinet, do not switch directly through electric filter or switch blade, in order that pump run well.
5. Do not work under lower head for a long time (commonly the using head can not below rated head 60%). It's better work within the advised using head, in case the pump overload and motor burned.

MAINTENANCE

1. The pump needs special person to manage and use, check whether has a good insulation between winding and casing on schedule.
2. After working in a high viscosity liquid, should water pump for few minutes, preventing sediments store in the pump, ensure pump cleanliness.
3. Generally, after every 300-500 hours work should add or replace mechanical oil in oil house (oil No.: 10-30), keep mechanical seal lubricate, then enhance mechanical seal's life-span.
4. The seal ring between impeller and pump body has advantage on air-proof, once damaged will affect performance of pump directly, so replace when necessary.

十二、常见故障分析及其排除方法

故障现象	原因分析	排除方法
流量不足或不出水	<ol style="list-style-type: none"> 1、叶轮旋转错误 2、阀门是否打开和完好 3、管道叶轮被堵 4、转速过低 5、扬程过高 6、抽送介质密度较大和精度较高 7、密封圈损坏(口环处) 	<ol style="list-style-type: none"> 1、调整叶轮旋转方向 2、检查、维修、排除 3、清理杂物 4、检查电器设备及电路 5、改泵或降低扬程 6、用水)中稀降低浓度和粘度 7、更换
运行不稳定或泵不能启动	<ol style="list-style-type: none"> 1、叶轮不平衡 2、轴承损坏 3、缺相 4、叶轮卡住 	<ol style="list-style-type: none"> 1、送制造厂调换或校正 2、更换 3、检查电路进行修复 4、排除杂物
电流过大	<ol style="list-style-type: none"> 1、工作电压低 2、管道叶轮受阻 3、使用扬程过低 4、抽送液体的高度或粘度较高 	<ol style="list-style-type: none"> 1、调整工作电压 2、清理管路叶轮结构 3、减少流量，提高扬程 4、改变或粘度
泵有杂音或振动	<ol style="list-style-type: none"> 1、泵轴、电机轴不同心 2、介质中有气体 3、腐蚀使泵轴不平衡 4、传动装置处螺栓松动 5、泵轴弯曲 	<ol style="list-style-type: none"> 1、调整 2、降温或加压 3、更换 4、紧固 5、校直或更换

FAILURES ANALYSIS AND TROUBLESHOOTING

Failure	Cause analysis	Troubleshooting
Flow insufficient or no water out	<ol style="list-style-type: none"> 1、 Impeller moving wrong 2、 Whether the valve open or good 3、 Pipe and impeller blocked up 4、 Too low rotating speed 5、 Too high head 6、 Too high concentration of the medium to be extracted 7、 Oral ring damaged 	<ol style="list-style-type: none"> 1、 Adjust impeller moving direction 2、 Check, maintenance and eliminate 3、 Get rid of foreign matters 4、 Check the electric equipment and circuit 5、 Change the pump and lower the head 6、 Lower consistency with water 7、 Replace
Instability running or unable to start	<ol style="list-style-type: none"> 1、 The impeller is not balance 2、 The bearing damaged 3、 Lack of phase 4、 Impeller blocked 	<ol style="list-style-type: none"> 1、 Deliver to exchange or adjustment 2、 Replace 3、 Check the pipeline and repair it 4、 Get rid of sundries
Too heavy current	<ol style="list-style-type: none"> 1、 Low voltage 2、 The pipeline and impeller blocked up 3、 Too low using head 4、 Too high density or viscosity of liquid extracted 	<ol style="list-style-type: none"> 1、 Adjust voltage 2、 Get rid of blocked matters 3、 Reduce flow and enhance head 4、 Change density and viscosity
Low insulation resistance	<ol style="list-style-type: none"> 1、 The electrical contraction of cable is leakage 2、 Cable damaged 3、 Mechanical seal worn out and water-leakage 4、 Every O-seal ring is useless 5、 The casing eroded by medium cause water-leakage 	<ol style="list-style-type: none"> 1、 Tighten the clamp nut 2、 Replace 3、 Replace 4、 Replace 5、 Repair